

BEARINGS FOR THE PETROCHEMICAL INDUSTRY

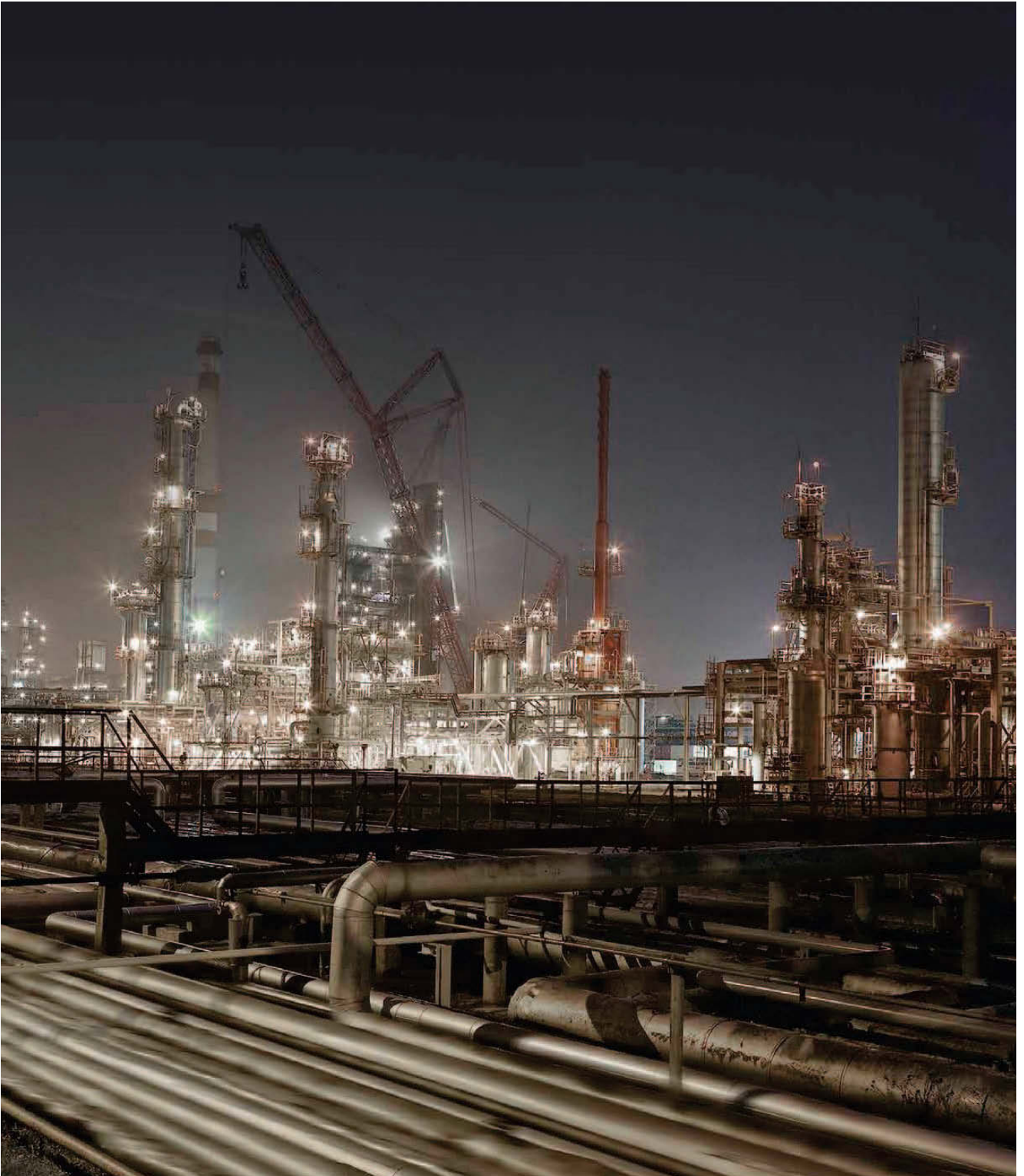

SUBSCRIBE TO NSK NEWSLETTER 

Keeping your production equipment at
the highest level of performance and reliability





Companies in the Petrochemical Industry need bearings that are able to increase mean time between failures (MTBF), minimise costly downtime and reduce loss of productivity. The machine components used in this sector – such as pumps, compressors, electric motors and ventilators – are extremely sensitive. As a global supplier to the world’s leading manufacturers in these industries, NSK has the experience and expertise to help its customers manage their costs and improve production efficiency.

Please find below examples of strategic equipment where you cannot accept bearing premature failures:

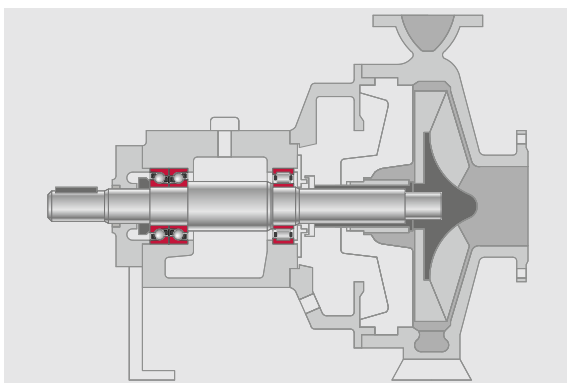

Centrifugal Pumps

Bearing Selection

- › Cylindrical Roller Bearings
- › Angular Contact Ball Bearings
- › Double Row Angular Contact Ball Bearings
- › Deep Groove Ball Bearings – special: HR series

Operating Conditions

- › Speed: 1500 rpm – 3000 rpm
- › Axial & radial loads

Bearing Requirements

- › Long life under high axial loads
- › Small axial free play

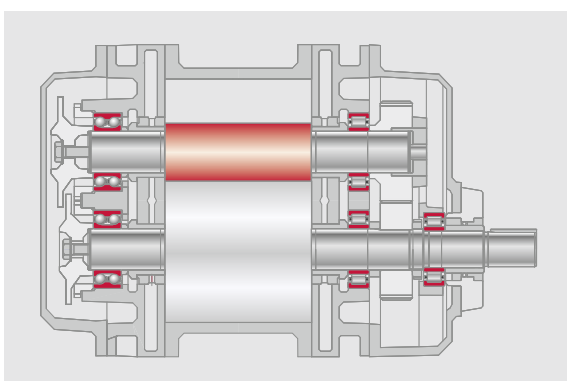

Roots Blower

Bearing Selection

- › Cylindrical Roller Bearings
- › Angular Contact Ball Bearings
- › Double Row Angular Contact Ball Bearings
- › Deep Groove Ball Bearings

Operating Conditions

- › Oil-free
- › Medium to high temperature
- › Vibration

Bearing Requirements

- › Long life
- › Heat resistance

Explicit requests demand precise solutions

NSK is introducing a new series of bearings in order to increase mean time between failures (MTBF). This new series enables you to reduce your operating costs by improving bearing life for very sensitive equipment such as pumps.

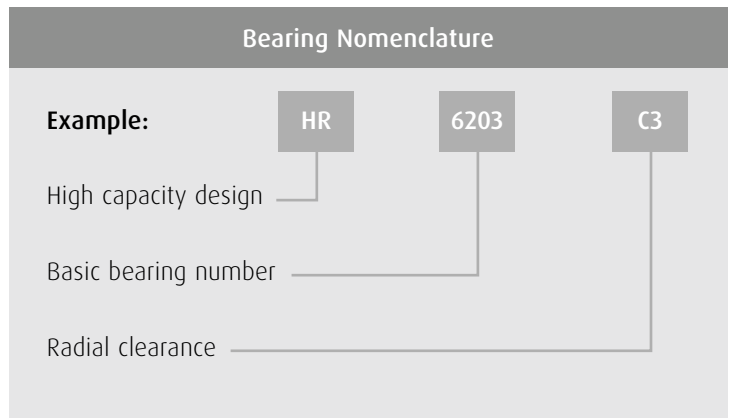

Bigger rolling elements:
load capacity increased

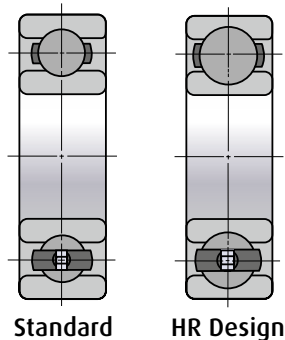

High-capacity deep-groove ball bearings

The HR series of high-capacity deep-groove ball bearings features a special internal design, allowing for larger rolling elements than standard deep-groove ball bearings. However, the external dimensions remain the same, according to ISO standards. These new bearings increase dynamic load ratings by 7% to 19% (depending on size), resulting in a 22% to 68% increase in ISO life. In this way, the HR series can improve the life of your machine, minimising the costly downtime you would otherwise face.

Cost Saving – Petrochemical Refinery

Using HR deep-groove ball bearings saves a refinery more than €27,000 a year

A petrochemical refinery plant was experiencing recurrent failures of a cylindrical roller bearing in a critical centrifugal pump. The transition from belt drive to direct drive on the pump led to unexplained bearing failure, resulting in costly downtime. Thanks to the implementation of our Asset Improvement Programme (AIP), the problem was analysed and identified.

In addition to providing high-quality products, it is also our duty to help make your machines more reliable by providing a range of technical, consultancy, analytical and commercial value-adding services.

The NSK engineers investigated the application conditions and found the reasons behind this recurrent bearing failure. They discovered that switching from a belt-driven to a direct-driven configuration drastically reduced the radial load on the bearing, which led to rollers slipping on the inner raceway. The bearing was successfully replaced with an NSK HR deep groove ball bearing, as the minimum radial load was lower than those of the cylindrical roller bearing and the load capacities were sufficient to match the application requirements.

Thanks to the AIP programme, machine reliability at the refinery improved and our customer saved more than €27,000 per annum.

COST SAVINGS
PETROCHEMICAL REFINERY

MOTION & CONTROL
NSK

History

A petrochemical refinery plant was experiencing recurrent failures of a cylindrical roller bearing (NU311) in a critical centrifugal pump. Transition from belt-drive to direct-drive of the pump led to the unexplained bearing failure, resulting in costly downtime.

Actual Cost Saving

€ 27,845

Cost Saving Description

- Long Life
- Material Substitution
- Reduced Maintenance
- Technical Support



Corrective Measures

NSK investigated the application conditions and the failed bearing and found the solution. The switch from belt-driven to direct-driven configuration has drastically reduced the radial load on the NU311 which has led to rollers slipping on the inner raceway. Bearing NU311 was successfully replaced by a deep groove ball bearing 6311.

Cost Saving Breakdown

OLD DESIGN	Cost p.a.	NSK DESIGN	Cost p.a.
Old bearing costs	€ 150	New bearing costs	€ 25
3 breakdown x 2 fitters x 6 hours x € 20/hour	€ 720		
3 breakdown x 6 hours x € 1.500/hour	€ 27.000		
Total Cost Per Year € 27.870		Total Cost Per Year € 25	

www.nsk-europe.com

CS-E-2012

Innovative products for increased productivity



Cylindrical Roller Bearings with L-PPS Cage

- › Optimised internal design
- › L-PPS cage with superior heat and wear resistance
- › High load capacity
- › Improved lubricant flow



NSK HPS Angular Contact Ball Bearings with L-PPS Cage

- › High load capacity
- › High rotating speed
- › High precision: P5 (ISO Class 5) running accuracy
- › Universal facing
- › Tight axial clearance/preload tolerance
- › 40 degree Contact Angle
- › L-PPS cage with superior heat and wear resistance



Creep-Free Bearings

- › Prevents creeping
- › No special machining of the housing is required
- › Easy to assemble
- › Reusable housing



LNG Pump Bearings

- › Can run immersed in Liquefied Natural gas, up to -162°C at speeds up to 3600Rpm
- › Self-lubricating cage
- › Inner & outer rings in stainless steel
- › Rolling elements in stainless steel
- › Maintenance intervals extended



Sealed Single Row Deep Groove Ball Bearings for High Temperature

- › Viton seals
- › Can run up to 150°C
- › Low noise level
- › Stabilised rings



High Capacity Deep Groove Ball Bearings (HR series)

- › Special internal design
- › Bigger rolling elements
- › Increased dynamic load rating
- › Increased life in operation
- › Interchangeable with the standard range

This is a non-exhaustive overview of NSK bearings used in the Petrochemical Industry. If you require additional bearings, please contact NSK.

Standard Bearing Range



NSK HPS Angular Contact Ball Bearings with Brass Cage

- › Optimised internal design
- › High strength ball guided brass cage
- › High running accuracy P5 (ISO Class 5)
- › High load ratings
- › Universal facing in standard
- › 40 degree Contact Angle



Single Row Cylindrical Roller Bearings with Brass Cage, Steel Cage or Polyamide Cage

- › Pressed steel cage series: EW
- › Polyamide cage series: ET
- › Machined brass cage series: EM



Double Row Angular Contact Ball Bearings

Available ranges: 3200 – 3300 / 5200 – 5300 Series

- › Steel or polyamide cage
- › Open
- › Shielded ZZ or 2Z
- › Sealed DDU or 2RS



Single Row Radial Ball Bearings

Available ranges: 600, 6800, 6900, 16000, 16100, 6000, 6200, 6300, 6400 Series

- › Standard and special applications
- › Steel, brass or polyamide cage
- › Low noise
- › Full sealing options
- › Wide range of greases
- › Standard or special steels



Tapered Roller Bearing

- › Inch & metric sizes
- › Standard steel / carburised steel / HTF treatment
- › Custom-made sets with spacers



NSK HPS Spherical Roller Bearings

- › High load capacity
- › High limiting speed
- › High strength cage (steel or brass)
- › Low noise and vibration



Plummer blocks

To ensure effective sealing, plummer blocks are available with a variety of special seal options and end covers. The benefits include a facility for easy mounting and dismounting of pre-assembled shafts.

Getting to the heart of service: the AIP Value Cycle

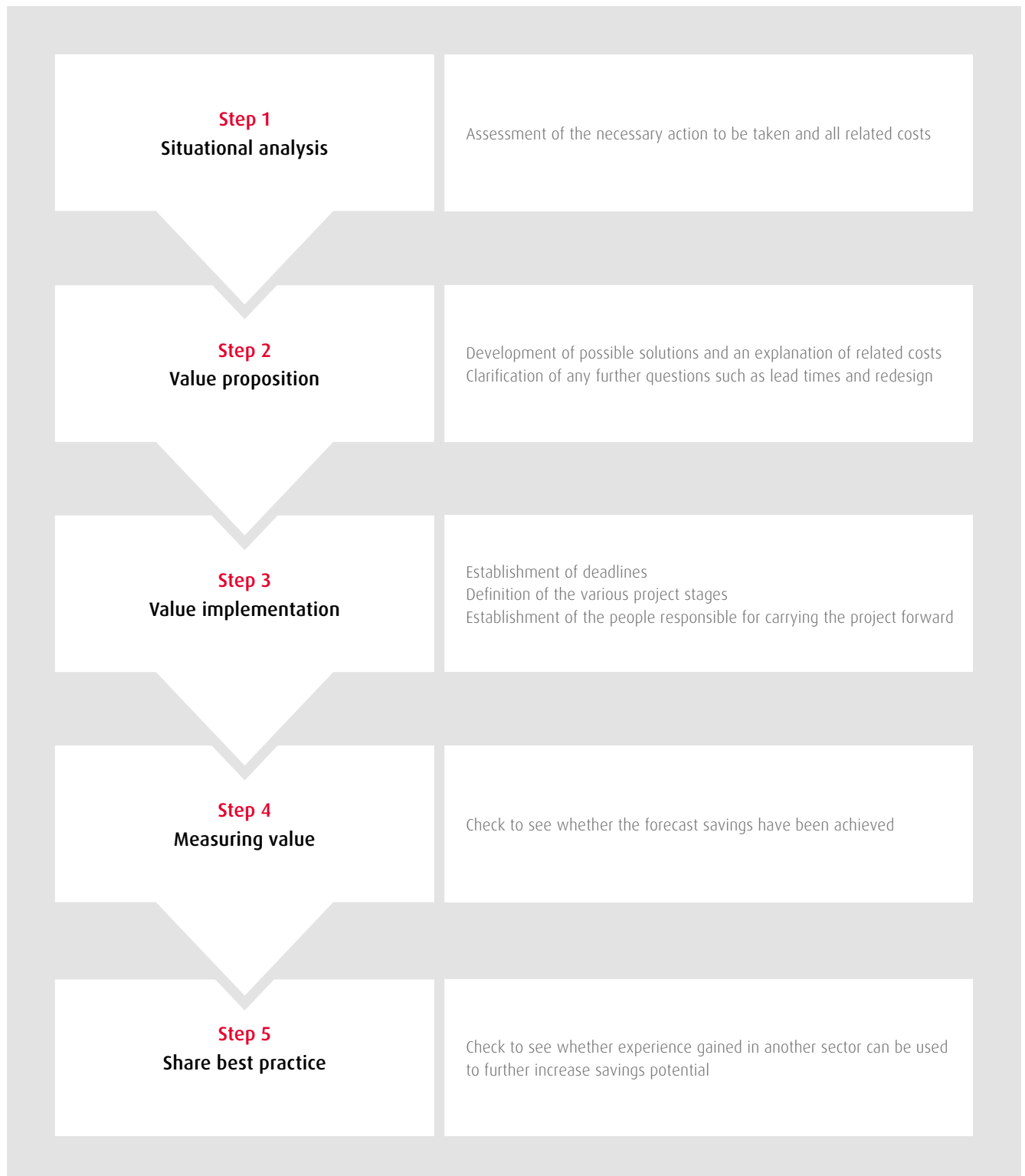



To be the manufacturer and distributor of good products is not enough nowadays; we believe that being an active partner with a broad spectrum of services to support our clients is more important. Our highly experienced staff are on the ground and ready to work with you directly to find individual solutions for smooth, efficient and profitable production processes in your company.

Increased profitability thanks to AIP

Less machine and plant downtime. Cost reduction without affecting quality. With AIP, a well-proven asset improvement programme, we help you to recognise, and act on, profitability potential. The programme combines existing knowledge in your field of competence and your corporate processes with the latest NSK technical knowledge.

Starting with a situational analysis, we compile a structured catalogue of measures together with you and assist you with its implementation. A Measuring Value check ensures that you achieve the sought-after advantages inside the agreed time frame.

Additionally, we offer training courses, carry out specialised service and repair services in our NSK Service Centres, and continually expand our online applications on our secure client site.



NSK Service Spectrum

Technical Support	Training Courses	Analytical Services	Value Added Services
Application Reviews	Introduction to Bearing Technology (Parts 1 & 2)	Failure Mode Analysis	NSK Cost Down Approach
Engineering Support	Best Practice Fitting & Removal of Bearings (Sections 1 & 2)	Material Analysis	Maintenance Schedules
Machine Design Consultancy	Bearing Diagnostics	OEM Part Conversion	Site Surveys
Bearing Surveys	Application of Bearings	Standardisation & Rationalisation	Maintenance Tool Audits
Diagnostic & Vibration Analysis	Sector Specific		Super Precision Service Package
	Food & Beverage Pumps & Compressors Quarry, Mining & Construction	Paper, Metals & Steel Machine Tool, Railway	